

YOUR
FIRST CHOICE



First Floor[®]

CONCRETE

www.firstfloor.com.pk



OUR STORY

Established in 1997, First Floor offers the finest selection of flooring and office furniture solutions, especially designed and seasoned to suit local requirements. First Floor has been the trendsetter in innovative flooring and workplace solutions in Pakistan. With over two decades of imagination, excellence, and innovation, we are proud to be the exclusive distributors of the world-leading European flooring brand 'Tarkett' in Pakistan, offering a wide range of products including laminate, wood, vinyl, linoleum, carpet tiles, synthetic turf, and sports surfaces.

First Floor is also proud to be the exclusive distributor of the leading office furniture brand 'Rockworth' in Pakistan. For 44 years, Rockworth has been the international leader in design, manufacturing & delivery of workspace solutions.

CORE VALUES

- Quality
- Service
- Safety
- People
- Environment

WHY FIRST FLOOR CONCRETE

- Guaranteed high-quality of concrete products via high-tech German-designed plant
- Backed by First Floor's 20-year experience and reputation in the flooring sector
- Long lasting, strong products due to latest technology and superior quality of raw materials

URBAN

The Urban rectangular concrete pavers are versatile, and easy to install. Our 50mm, 60mm, and 80mm pavers come in a variety of colors. They are designed to take heavy loads, and for this reason are suitable for installations in high-traffic areas.

SPECIFICATIONS			
PRODUCT	THICKNESS	LENGTH	WIDTH
URBAN	50 mm	198 (+2mm)	98 (+2mm)
	60 mm	198 (+2mm)	98 (+2mm)
	80 mm	198 (+2mm)	98 (+2mm)

*Tolerance ± 2 mm on sides ; ± 3 mm on height

Strength: 5000 - 8000 psi (after 28 days of curing)

COLOR

Grey, Charcoal Grey, Terracotta, Sandstone

Special colors can also be developed on client's request

IDEAL FOR

- Roads
- Footpaths and walkways
- Driveways
- Courtyards
- Parks and gardens
- Bus stops
- Bridge ramps and underpasses
- Parking areas
- Port terminals
- Airports
- Patios
- Landscaping

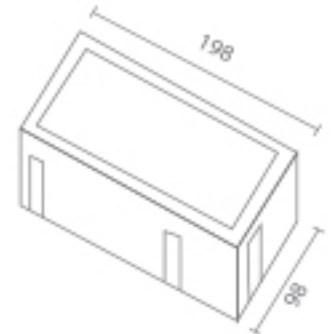

ARCADE

Combining two different shapes in one paver, Arcade interlocking pavers provide a combination of aesthetics and functionality. Available in various colors, they are meant for heavy duty applications and can do wonders to any space.

SPECIFICATIONS

PRODUCT	THICKNESS	LENGTH	WIDTH
ARCADE	60 mm	196 (+2mm)	118 (+2mm)

*Tolerance ± 2 mm on sides ; ± 3 mm on height

Strength: 5000 - 8000 psi (after 28 days of curing)

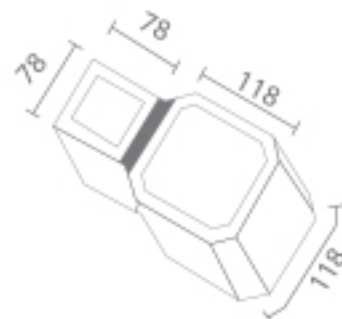

COLOR

Grey, Charcoal Grey, Terracotta, Sandstone

Special colors can also be developed on client's request

IDEAL FOR

 Jogging tracks
 Gardens

 Driveways
 Walkways

 Patios
 Landscaping

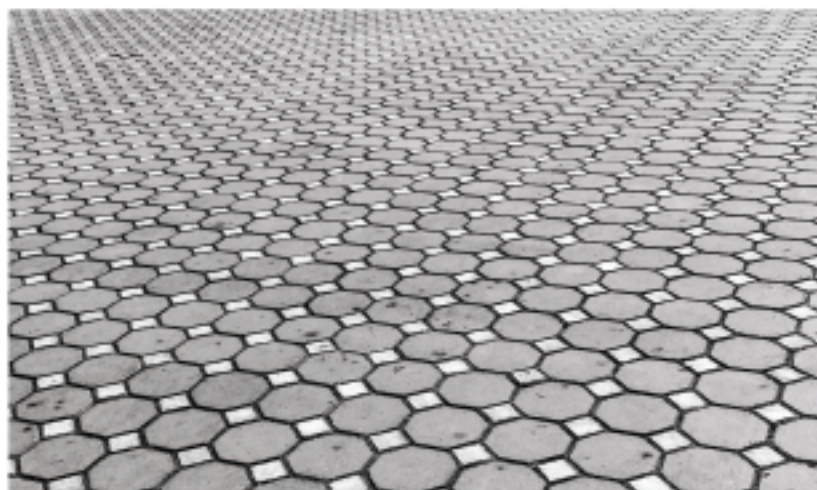

KERB-STONE

Kerb-stone is of high importance in urban design. First Floor's kerb-stones provide heavy-duty edging for pavements and roads. The slanting profile is particularly suited to providing a check to motorists if they are close to the edge of a road.

SPECIFICATIONS

PRODUCT	THICKNESS	HEIGHT	WIDTH
KERB-STONE	150 mm	450 mm	300 mm

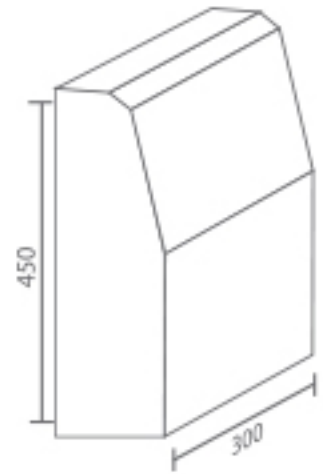

COLOR

Natural Grey

Special colors can also be developed on client's request

IDEAL FOR

- Footpath edges
- Road edges
- Driveway edges
- Pathways



OUR PLANT



Model: ZN900C



First Floor has acquired a state-of-the-art German designed plant in its mission to ensure better quality and life of the products it produces. The plant is a product of QGM Zenith Group and has been designed in Germany.

FEATURES

1) HIGH-EFFICIENT VIBRATION

QGM ZN900C is equipped with a dual vibration system. The vibration table consists of dynamic and static table, which greatly improves the vibration efficiency. The dual vibration mode ensures not only high strength through better compaction, but also guarantees high quality finish of final products.

2) EFFICIENT HYDRAULIC SYSTEM

The plant comes with a dynamic proportional valve and constant output pump to adjust oil speed and pressure, thus ensuring stability, efficiency and energy-saving.

3) FREQUENCY CONVERSION CONTROL AND ENERGY-SAVING

Powered by Siemens Frequency Control system, it can save up to 30 percent of the electricity as compared to a traditional motor. At the same time, it greatly improves the consistency of concrete products whilst maintaining optimal quality.

4) FULLY AUTOMATED

QGM ZN900C is a 100% fully automated plant with easy operation, low failure ratio, and high reliability, ensuring both quality and consistency.

5) COMPULSORY FEEDING

The feeding frame, bottom plate, and mixing blades are made of heavy-duty HARDOX steel. This strengthens the sealing properties of the end product and prevents material leakage. Discharging gate is also controlled by automated SEW motor ensuring a perfect product with a longer lifespan than ordinary concrete products.

First Floor
CONCRETE

HEAD OFFICE:

20-C, 26th Street, Tauheed Commercial Area, Phase V, DHA, Karachi. Tel: 021-35304261-62-63

FACTORY:

Survey #749, Mauza Pathra, Tehsil Hub, Lasbela, Hub Balochistan

www.firstfloor.com.pk | concrete@firstfloor.com.pk | fb.com/firstfloorpakistan | instagram.com/firstfloorpakistan